

TC51 Series - CliniLever® Surgical Type 51

Specification Data Sheet



Standard Features

- Inline inlet tails with isolator and strainers.
- Components fully enclosed to avoid contaminants.
- Low lying levers allow easy to use hands free operation.
- Angled spout to help minimise the risk of water becoming trapped.
- Smooth easy clean surface.
- Smooth round design to facilitate easy cleaning and help reduce dirt and bacterial growth.
- Laminar flow nozzle to reduce the risk of Legionella comes standard.

To Specify

The AS/NZS 3718 Watermark approved TC51 Series CliniLever® Surgical Unit, complies to AS6400-2005 WELS 4 Star Rating and is supplied standard with a gooseneck outlet and laminar flow nozzle, 150mm long lever handles and a patented built in removable strainer and isolator, 1/2" BSP female removable inlets and is finished in bright chrome plate.

Code:

TC51FC1C - CliniLever® CP-BS Hospital Wall Mixing Set Type 51 Fixed, 150mm Lever Handles, Ceramic Disc



A family
owned
Australian
business



Performance Standards & Approvals

- AS/NZS 3718 – WaterMark
- WELS 4 Star Rating



Typical Dimensions

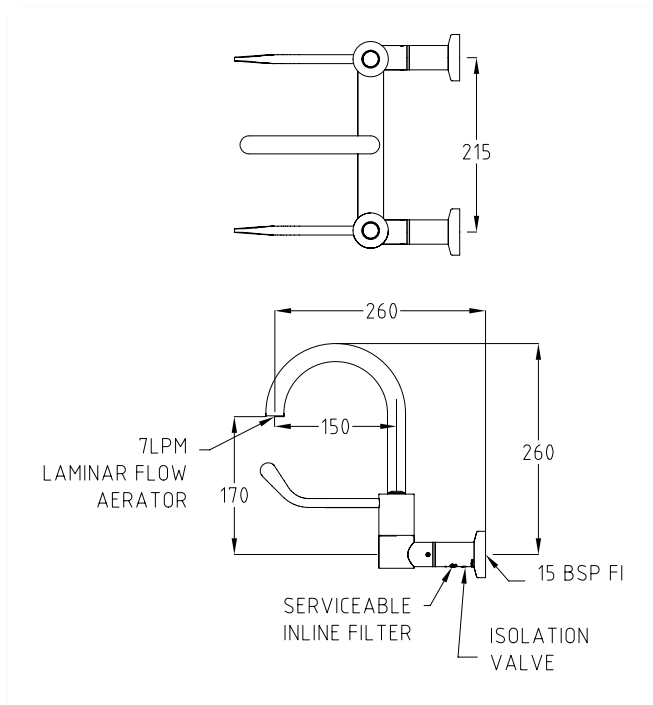

Technical Information

- Inlet: 1/2" BSP - Female
- Outlet: Laminar Flow
- Headwork: Ceramic Disc
- Working Pressure Range (kPa): 50 Min - 500 Max
- Working Temperature Range (°C): 5 Min - 65 Max
- Nominal Flow Rate (LPM): 6.74
- Construction: Brass
- Finish: Chrome

Maintenance & Cleaning

Galvin Engineering products should be cleaned with a soft damp cloth using only mild liquid detergent or soap and water. Do not use cleaning agents containing a corrosive acid, scouring agent or solvents. Do not use cream cleaners, as they are abrasive. Use of unsuitable cleaning agents may damage the surface. Any damage caused in this way will not be covered by warranty.

Regular maintenance should be carried out in accordance with the installation and troubleshooting guides provided with the product, relevant Australian Standards, local authorities and state codes.

As part of maintaining a safe and reliable plumbing system, we recommend tapware and valves are operated on at least a daily basis.

Warranty

Galvin Engineering products are covered under our Manufacturer's Warranty at www.galvinengineering.com.au. Galvin Engineering products must be installed in accordance with the installation instructions and in accordance with AS3500 and the PCA, relevant Australian Standards and local authorities applicable to product being installed. Water and electrical supply conditions must also comply to the applicable national and/or state standards, failing to comply with these provisions may void the product warranty and affect performance of the product.

Whilst all reasonable care has been taken in compiling the information in this document, the designs, dimensions and products shown are indicative only and should not be relied upon without our prior approval. Due to our policy of continuous development, we reserve the right to alter any details of specifications or products without notice. All information, drawings, technical specifications and product designs remains the property of Galvin Engineering Pty Ltd.

Within Australia: **1300 514 074** Outside Australia: P: +61 (0)8 9338 2344
 F: +61 (0)8 9338 2340
sales@galvinengineering.com.au
www.galvinengineering.com.au
 ABN: 78 008 719 382

GalvinEngineering 
the mark of reliability

PERTH | SYDNEY | MELBOURNE | BRISBANE | ADELAIDE | UNITED STATES OF AMERICA | UNITED KINGDOM | NEW ZEALAND